



LUXURY IN MOTION  
BORN TO PERFORM



JBM

BORN FOR  
LUXURY

# JBM Group

---

JBM Group is a \$3bn global Indian conglomerate, with 4 decades of excellence in driving product innovation & value across segments like Automotive, Buses & Electric Vehicles, EV Charging Infrastructure, EV Aggregates, Renewable Energy, and Artificial Intelligence. JBM has an infrastructure of 60 manufacturing plants, 5 engineering & design centres and is present in 37 countries today.

We are one of the world's integrated EV ecosystem players. The Group has developed an entire range of in-house EV solutions i.e. 'Well-to-Wheel', making us a one-stop solution provider in the E-mobility domain. JBM has been working purposefully towards building a comprehensive and intelligent EV ecosystem that seamlessly integrates Electric Vehicles, Battery Technology, Fast Charging Infrastructure, and Power Electronics among others.

JBM Group has been the vanguard of this evolution, pushing consensus for clean mobility and leading the growth chart of EV adoption in India. Our experience and expertise in this segment have allowed us to develop an end-to-end ecosystem for electric mobility.

Our foray into the Luxury Coach segment has enabled us to become the first Indian bus manufacturer to offer a complete range of EV products to cater to all customers' needs. It has been our consistent endeavor to contribute to the realization of the incredible vision of Global Net Zero targets and make our E-Verse ecosystem a sustainable reality.



# Luxury Envisioned and Comfort Redefined

---

The success of our Electric Vehicles has been the catalyzing ingredient for us to foray into the luxury electric coach segment. Our passion to offer an unparalleled luxury driving experience and vision to propel avant-garde characteristics in our E-vehicle has enabled us to roll out our electric luxury coach **Galaxy**.

The high performance & durability of our battery systems with their prowess controlled by unique battery management systems make Galaxy a compelling combination of a state-of-the-art product with world-class craftsmanship and excellent interiors for ultimate comfort and safety. Galaxy will be made available for private tours, airport & executive transfers, hotel transport, and vacation packages among others for individuals, groups, and companies.

The modularity of the battery packs along with their light weight leads to higher passenger occupancy & increased revenues and thus Galaxy provides highly competitive 'total cost of ownership'. For smooth operation of our coaches across global locations, we are offering ultra-fast charging along multiple routes with round-the-clock availability of services and spare network for 100% uptime, ensuring customer delight – making Galaxy the only choice of Luxury EV coach.

With a commitment towards curating sustainable solutions, we aim to create a happy and healthy planet for our future generations. Conserving the environment is the key focus area for our ESG goals.

I welcome you to JBM's E-Verse, the complete EV ecosystem universe, with Galaxy at the apex for creating exhilarating experiences.



# Designed to Outperform

Simplifying cutting-edge technology and making it affordable and user-friendly

- Best-in-class, modern, and technologically superior electric coach with global benchmarks in performance, luxury, comfort, safety, and innovation
- Advanced Lithium Ion battery packs with optimum energy consumption for propulsion, leading to higher savings
- Modular battery packs to cover entire range requirements of customers
- CCS2 DC fast charging for seamless integration with battery and quick turnaround time
- Permanent magnet synchronous motor with high torque and power delivery
- BMS, VCU, and telematics to enhance vehicle health, safety, and performance
- Regenerative braking system for enhanced range



# Luxuriously Comfortable

Innovatively designed for ultimate  
comfort

- Electronically controlled air suspension offers smooth ride experience
- Luxury reclining seats with calf support
- Personalized reading lamps and AC louvers
- Large leg room for a comfortable long distance travel experience

# Safety Redefind

Curated and developed for providing unparalleled levels of safety

- EBS and ABS coupled disc brakes for excellent road control and stability
- High temperature cut-off for the battery and FDSS
- Surveillance cameras and VTS for supervising and managing buses
- World-class IM and IL safety standards
- Vehicles tested for 1 Million Kilometers - virtually and physically
- Product Life-cycle Management (PLM) ensures 100% reliability and safety
- Side-impact and rollover safety testing conformance
- Larger glass panels ensuring no-blind zones for safer driving





# Assured Fleet Operations

AI-based real-time vehicle and fleet monitoring

---

- Advanced telematics giving 24x7 access to vehicle's state of health
- Firmware over the air for remote updates
- Configurable and encryption data storage with Geo-fencing
- On-board diagnostic system
- PAN India 3S after-sales network
- Web and mobile apps for instant updates





# JBM Electric Bus Facility

*India's largest integrated EV bus plant has the right blend of automation to ensure world-class quality standards.*

*This state-of-the-art facility is widespread over a 4 million square feet area.*

- World's largest integrated dedicated EV ecosystem facility and E-bus manufacturing unit for producing up to 20,000 E-buses and special purpose vehicles.
- World-class infrastructure having an Integration of MES system, ERP system (SAP), and PLM & digital simulator, making it a complete digital factory.
- Transformed into a fully digital factory that can be monitored from a remote location and control room owing to the MES system, ERP system (SAP), PLM, and digital simulator integration.
- Real-time equipment health monitoring and early abnormality detection result in prompt preventative maintenance and minimal line stops.
- State-of-the-art Innovation Centers and Test Labs with new age materials, science, and technologies.
- Dedicated quality gates at the end of each line capturing digital data and providing real-time feedback.

# Dimensions

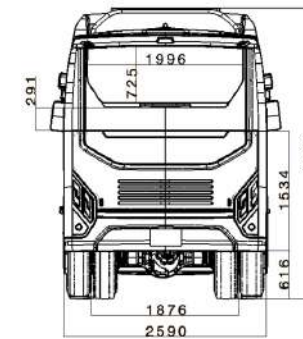
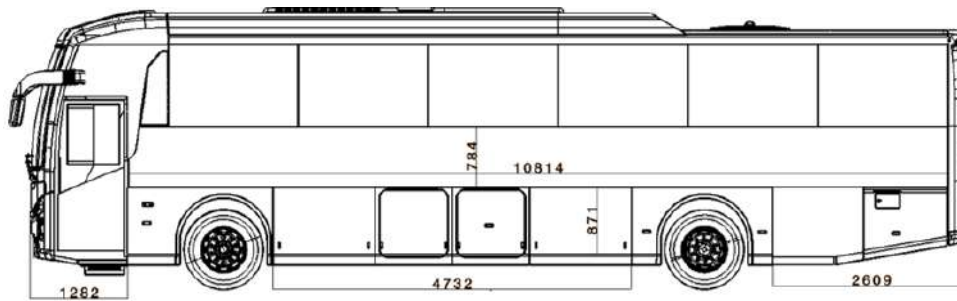
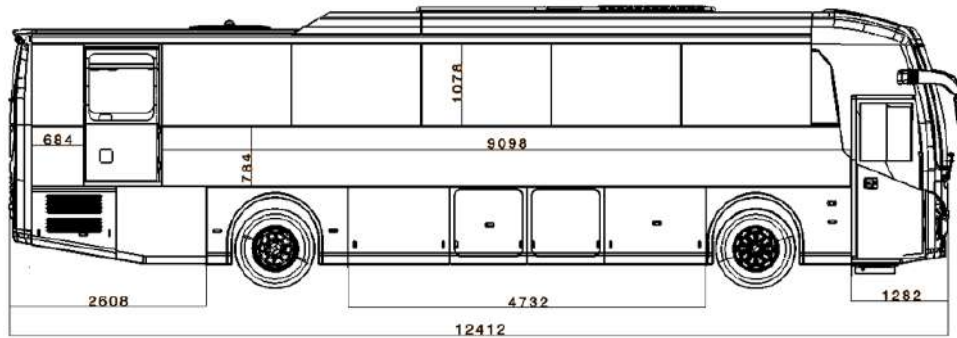

# Technical Specification

Vehicle Description	12M Coach
Vehicle Dimensions (L x W x H)	12400 mm X 2590 mm X 3695 mm
Wheel Base	6350 mm
Floor Height	1200 mm
Seating Capacity	49 Premium Reclining (2X2)+Driver+Co-driver
Passengers Seat Type	Luxury reclining; Calf support (optional)
Luggage Space	7 Cubic Meters
Driver Seat	4 way adjustable, with 3 point ELR seat belt
Front Axle	Heavy Duty Rigid Axle
Rear Axle	Fully Floating, single reduction Banjo Type
Suspension	Front & Rear Electronically Controlled Air Suspension
Brakes	All Disc Brakes with ABS, EBS, EVSC & fully air brakes
Kneeling System	Available
Tyres (Front & Rear)	295/80 R22.5 Radial Tubeless
Structure & Bus Body	High strength Corrosion resistant monocoque structure and Bus body as per AIS 052
Exterior Panels	Front & Rear FRP; Side panel Aluminum, Stretched steel (optional)
Emergency Exits	Yes

Vehicle Description	12M Coach
Passenger doors	Automatic In-Swing door
Traction Motor	Permanent Magnet Synchronous Motor 250 KW Max. Power
Steering System	Electrically driven & Hydraulic power assisted steering with Tilt & telescopic mechanism
Max Speed	80 kmph
Battery Type	Advanced Li-ion chemistry
Regenerative Braking System	Yes
Charging System	Plug-in fast charging (CCS-2)
HVAC	Yes
Driver's Comfort & Convenience	ECAS, EBS, EVSC, Hill hold, ADAS (optional)
Passenger's Comfort & Convenience	Seat Calf support optional, Individual AC Louver & Reading Lamp, USB Charging, Vehicle Tracking, Bus kneeling for ease of boarding
HV Safety	Protection against Surge , Short Circuit & Overload Constant insulation monitoring and Interlock for safety
Daily Operational Range	1000 kms



**Corp. Office**

Plot No.9, Institutional Area, Sector 44, Gurgaon, Haryana-122003

**Sales & Marketing office - JBM Electric Vehicles Pvt. Ltd.**  
601, Hemkunt Chambers 89, Nehru Place, New Delhi - 110019



[www.jbmbuses.com](http://www.jbmbuses.com)  
[www.jbmgroup.com](http://www.jbmgroup.com)



[corp.communications@jbmggroup.com](mailto:corp.communications@jbmggroup.com)



Enquiry No. +91-7899980008 (South) | +91-9953993923 (North & East) | +91-8238144400 (West)  
Landline No. +91-11-26427104, 42099900